



Comprehensive eManifest Deployment 4 Notices Walkthrough:

Freight Forwarders

*Project Communications and Stakeholder
Engagement*

PROTECTION SERVICE INTEGRITY INTÉ
GRITÉ **PROTECTION** SERVICE INTEGRITY
INTÉGRITÉ PROTECTION **SERVICE** INTEG
RITY INTÉGRITÉ PROTECTION SERVICE
INTEGRITY INTÉGRITÉ PROTECTION SER
VICE INTEGRITY INTÉGRITÉ PROTECTION
SERVICE INTEGRITY INTÉGRITÉ PROTEC
TION SERVICE INTÉGRITÉ PRO
TECTION SERVICE INTÉGRITÉ
PROTECTION SERVICE INTÉGRITÉ INTÉ
GRITÉ PROTECTION SERVICE INTÉ
GRITÉ PROTECTION SERVICE INTÉGRITY
INTÉGRITÉ PROTECTION SERVICE INTEG
RITY INTÉGRITY INTÉGRITY INTÉGRITY
INTÉGRITY INTÉGRITY PROTECTION SER
VICE INTEGRITY INTÉGRITÉ **PROTECTION**
SERVICE INTEGRITY INTÉGRITÉ PROTE
CTION SERVICE INTEGRITY **INTÉGRITÉ** SER
VICE INTEGRITY INTÉGRITÉ PROTECTION





Presentation Overview

- eManifest Functionality Expected in Fall 2015
 - Notices
- eManifest Fall 2015 Notices
 - Document Not On File Notice
 - Completeness Notices
 - Non-Consolidated Completeness
 - Consolidated Completeness
 - Disposition Notices
 - Reported
 - Arrived
 - Released
 - Held
 - Authorized To Deliver
 - Deconsolidation Notice
 - Key Notice Data Elements
- Deployment 4 Notice Flows



eManifest Functionality Expected in Fall 2015

In Fall 2015, the CBSA expects to introduce new and enhanced notification systems to increase automation of pre- and post-arrival notices to clients on commercial movements.

- A subset of new eManifest notices, for EDI clients, will advise on the completeness of advance data submitted to the CBSA and on the arrival and release statuses of shipments.
- The new eManifest notices will be based on the overall shipment status.
 - Current notices are based on individual documents submitted by clients; Release Notification System (RNS) messages are based on the status of the release only.
 - The new eManifest notices will be based on the overall shipment status and notices will be transmitted against individual documents within a shipment whenever the shipment status changes.
- eManifest Portal users are not impacted and there will be no changes within the Portal environment.



eManifest Functionality Expected in Fall 2015

- Adoption of the new subset of eManifest notices will be voluntary to provide EDI clients the opportunity to transition to the end-state eManifest notices.
- Clients can also choose to receive legacy EDI notices, RNS messages, eManifest completeness notices, and the new subset of EDI eManifest notices concurrently, allowing clients to become familiar with the new notices before the RNS messages are eliminated.
- Clients will be able to coordinate their activities with CBSA's Technical Commercial Client Unit (TCCU) and will have the ability to filter the notices they receive.
- EDI clients will be required to build and test with the TCCU to receive the new notices. The draft Electronic Commerce Client Requirements Document (ECCRD) for the new EDI notices is currently available on request to the TCCU.



eManifest Functionality Expected in Fall 2015

Document Not on File Notice

The **Document Not on File** notice informs clients that a Cargo Control Number (CCN) that is not in good standing was quoted on a trade document submitted to and accepted by the CBSA.

- Documents that trigger this notice are a House Bill Close message, a PARS, an RMD, a B3 and an Integrated Import Declaration (IID). The notice will be sent automatically to the carrier that was quoted on the submitted document(s). Carriers will receive this notice for CCNs that have been cancelled, are rejected, or are not on file.
- Example: If a PARS is submitted by a broker for a CCN that is not on file, the carrier quoted on the PARS will receive the **Document Not on File** notice.



eManifest Functionality Expected in Fall 2015

Completeness (Pre-Arrival) Notices

The completeness notices are designed to assist clients in meeting the pre-arrival information requirements.

- Prior to arrival of the cargo at its port of destination, submission of pre-arrival trade documents will trigger completeness notices.
- Additionally, completeness notices will be sent when the shipment changes from least complete (one pre-arrival document submitted to the CBSA) to most complete (all pre-arrival documents submitted to the CBSA).
- Current pre-arrival messages sent by the CBSA through the Release Notification System (RNS) (e.g. Dec Accepted) will eventually be replaced by the completeness notices.



eManifest Functionality Expected in Fall 2015

Non-Consolidated Cargo Completeness (Pre-Arrival) Notices

The non-consolidated cargo completeness notices (least complete to most complete):

- **Not Matched** - informs clients that either no links to a related trade document have been established, or that a document that has previously been matched to another document becomes unlinked through a change or cancellation (e.g. when a PARS has been submitted but the related cargo has not yet been submitted, the PARS is **Not Matched**).
- **Matched** - informs clients that a specific trade document is linked to a related trade document (e.g. when a PARS has been submitted and the related cargo has already been submitted, then the PARS is **Matched**).
- **Cargo Complete** - informs clients that a non-consolidated primary cargo document has been submitted to and accepted by the CBSA. Documents that have achieved this status have not yet been linked to related PARS or IID documents.
- **Document Package Complete** - informs clients that the cargo and all other required pre-arrival trade documents – as well as all related release documentation necessary for the CBSA to determine if the goods can be released into the Canadian economy (e.g. PARS, IID) – have been submitted to and accepted by the CBSA.



eManifest Functionality Expected in Fall 2015

Consolidated Cargo Completeness (Pre-Arrival) Notices

The consolidated cargo completeness notices (least complete to most complete):

- **Not Matched** - informs clients that either no links to a related trade document have been established, or that a document that has previously been matched to another document becomes unlinked through a change or cancellation (e.g. when a House Bill Close has been submitted but the previous CCN has not yet been submitted, the House Bill Close is **Not Matched**).
- **Matched** - informs clients that a specific trade document is linked to a related trade document (e.g. when a House Bill Close has been submitted and the previous CCN has already been submitted, then the House Bill Close is **Matched**).
- **Cargo Complete** - informs clients that all of the related secondary cargo (e.g. House Bill) has been submitted to and accepted by the CBSA. Documents that have achieved this status have not yet been linked to related PARS or IID documents.
- **Document Package Complete** - informs clients that the cargo and all other required pre-arrival trade documents (House Bill, House Bill Close) – as well as all related release documentation necessary for the CBSA to determine if the goods can be released into the Canadian economy (e.g. PARS, IID) – have been submitted to and accepted by the CBSA.



eManifest Functionality Expected in Fall 2015

Cargo Completeness Comparison

Current:

- **Not Matched** applies to House Bill cargo, House Bill Close and legacy Multimodal Cargo.
- **Matched** applies to House Bill cargo, House Bill Close, legacy Multimodal Cargo and EDI PARS.

Fall 2015:

- **Not Matched** and **Matched** will apply to releases (i.e. PARS, IID), House Bill Close and consolidated cargo and will also be made available on legacy air and marine EDI cargo records.
- **Cargo Complete** will replace **Not Matched** for non-consolidated cargo.
- **Document Package Complete** replaces **Matched** for cargo and will also be made available on legacy air and marine EDI cargo records.



eManifest Functionality Expected in Fall 2015

Disposition Notices

The disposition notices inform clients about a shipment as it progresses through the commercial process.

- Once in Canada, cargo can be placed in a number of dispositions. Disposition notices will be generated when a decision relating to the shipment is updated by the CBSA.
- Once cargo has been 'arrived' at its destination, Conveyance Arrival Certification Message (CACM) or PIL-Arrival for FPOA-destined cargo, or Warehouse Arrival Certification Message (WACM) for in-bond), disposition notices will be generated for the related cargo.
- Current arrival messages sent by the CBSA through RNS will eventually be replaced by the new notices.
- Current post-arrival messages sent by the CBSA through RNS release messages will also be replaced by the new notices.



eManifest Functionality Expected in Fall 2015

Disposition Notices

The disposition notices are:

- **Reported** - informs clients that their cargo has been presented to the CBSA at the Port of Report or FPOA.
- **Arrived** - informs clients that their cargo has arrived at its Port of Destination.
- **Held for CBSA** - informs clients that their goods are being held for further determination or processing and cannot be released.
- **Released** - informs clients when goods have been authorized to be removed from a CBSA office, a sufferance warehouse or a bonded warehouse and released into the Canadian economy.
- **Authorized to Deliver** - informs Customs Self-Assessment (CSA) clients that their CSA goods can be delivered to the intended recipient.



Fall 2015 Notices

Other Notices

Additional Notice functionality:

- **Deconsolidation Notice** – The Deconsolidation Notice informs clients that the CBSA has authorized the transfer of Cargo control from a consolidated shipment to the related secondary House Bills that were submitted by a Freight Forwarder.
 - This notice can serve as electronic notification to the Warehouse Operator to allow the Freight Forwarder to take control of the goods within the consolidation. This notice can also serve as electronic notification to the party liable for Customs that the consolidated Cargo or House Bill has been acquitted.



Fall 2015 Notices

Notice Data Elements

In addition to the standard 'header' information shared by all notices, the new notices may also contain the following unique elements:

- **Completeness Notice** – CBSA Related Reference ID
- **Reported Notice** – Port of Report
- **Arrived Notice** – Port of Cargo Arrival, CBSA Sub-Location Code
- **Held for CBSA Notice** – Container ID
- **Released Notice** – Container ID, Special Instructions, Port of Release, CBSA Sub-Location Code
- **Authorized To Deliver Notice** – Port of Cargo Arrival, CBSA Sub-Location Code
- **Deconsolidation Notice** – Related Document Numbers (e.g. House Bills), Port of Destination, CBSA Sub-Location Code
- **Document Not On File Notice** – CBSA Related Reference ID



Trigger	RNS Messages	Current eManifest Notices	Fall 2015 Notices
Release accepted that references a CCN that has not yet been submitted.	Declaration accepted awaiting arrival	N/A	Document Not on File - Carrier Not Matched - Broker
Non-consolidated cargo submitted	No existing notice	Not Matched	Cargo Complete - Carrier
Carrier submits multi-modal cargo which links to PARS	No existing notice	Matched	Document Package Complete -Carrier Matched - Broker
CRN arrived	No existing notice	Section 12(1)	Section 12(1) - Carrier
Cargo reported	No existing notice	N/A	Reported – Carrier/Warehouse Operator (if destined inland)
Cargo arrived	No existing message	N/A	Arrived - Carrier/Warehouse Operator
Cargo referred for examination/decision	Goods requested for examination/referral	N/A	Held for CBSA – Carrier/ Warehouse Operator /Submitter of release
CSA Cargo achieves Auth to Deliver status	Authorized to Deliver	N/A	Authorized to Deliver - Carrier/Warehouse Operator (if destined inland)
Cargo released	Goods released	N/A	Released - Carrier/Freight Forwarder/ Warehouse Operator/Importer/ Account Security Holder



Notice Scenarios

Pre-Arrival Notices

1. Document Not on File Scenario
 - a) (Document Not On File)

2. Basic Flow
 - a) (Not Matched/ Matched/ Cargo Complete/ Document Package Complete)
 - b) (Reported/ Arrived/ Deconsolidated / Released)

3. Release Quoting House Bill Referred for Exam
 - a) (Held)

4. Two-Tiered Consolidation with Post-Arrival Release



1. Document Not on File Scenario



1. Document Not On File Scenario

Step 1: Freight Forwarder submits non-consolidated house bill

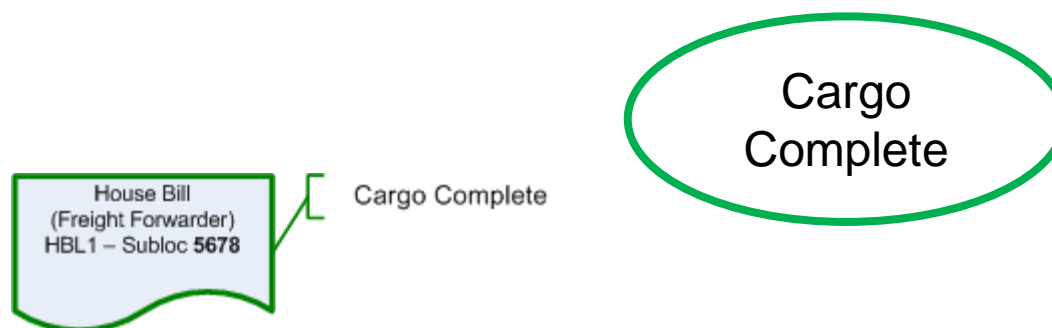

The Freight Forwarder submits non-consolidated house bill (HBL1)

- CBSA validates house bill document
- CBSA sends a notice to the freight forwarder indicating HBL1 is Accepted
- HBL1 status is set to **Cargo Complete** (non-consolidated house bills)
- CBSA sends a Completeness Notice to the freight forwarder indicating HBL1 is **Cargo Complete**.

1: Document Not on File Scenario

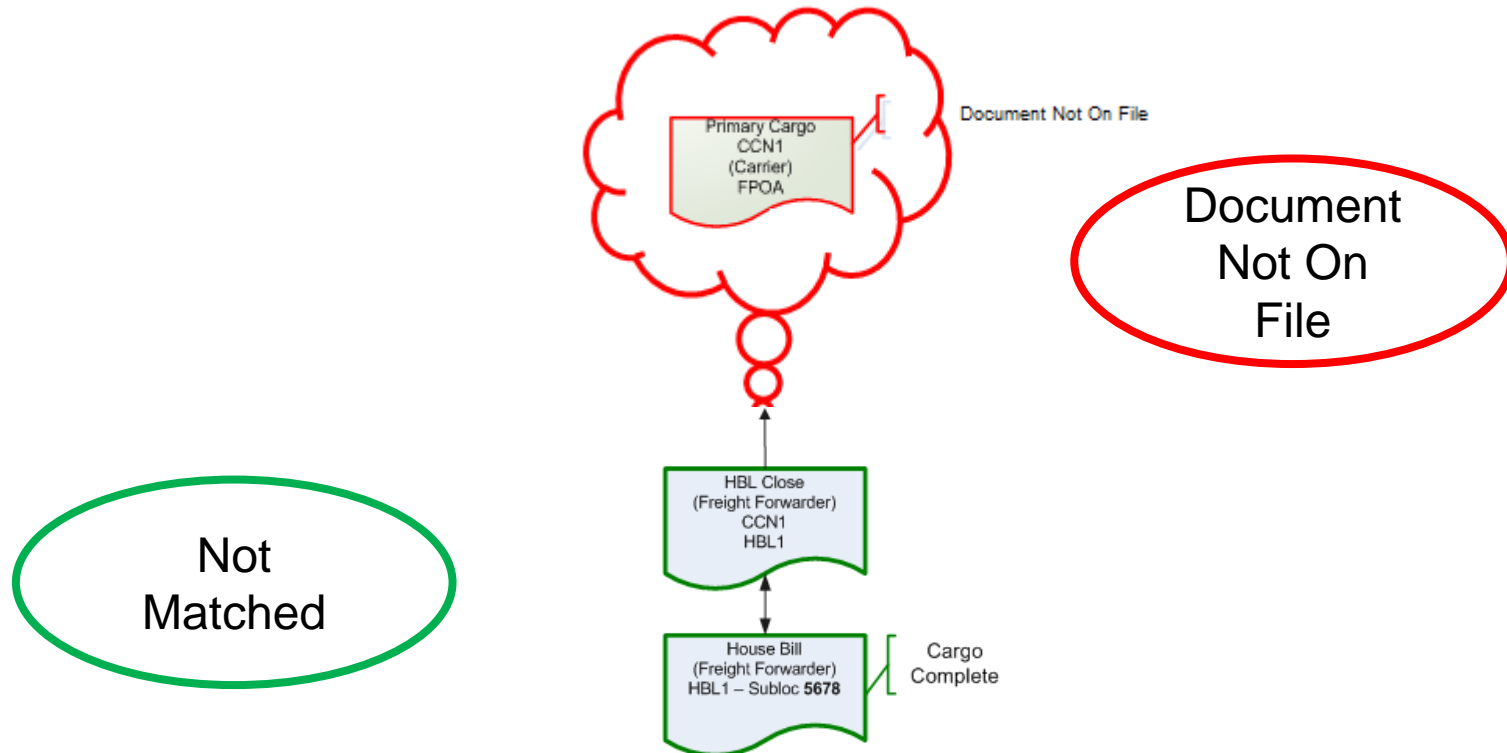

The Freight Forwarder submits House Bill Close message

- CBSA validates House Bill Close document
- CBSA sends a Notice to the freight forwarder indicating that the House Bill Close is Accepted
- House Bill Close status is set to **Not Matched**
- CBSA sends a Completeness Notices to the freight forwarder indicating House Bill Close is **Not Matched**.
- CBSA sends a Notice to the Cargo Carrier indicating CCN1 is **Document Not On File**.



2. Basic Flow



2. Basic Flow

Step 1: Freight Forwarder submits non-consolidated house bill



Freight Forwarder submits non-consolidated house bills (HBL1)

- CBSA validates house bill document
- CBSA sends a notice to the freight forwarder indicating HBL1 is Accepted
- HBL1 status is set to **Cargo Complete** (non-consolidated house bill)
- CBSA sends a Completeness Notices to the freight forwarder indicating HBL1 is **Cargo Complete**.



2. Basic Flow

Step 2: Carrier submits a consolidated cargo document

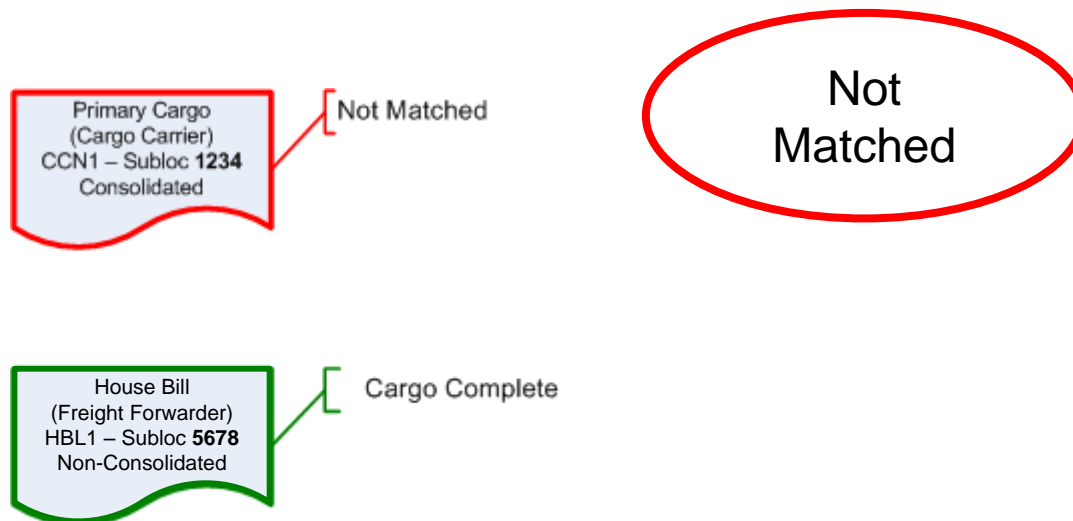

Carrier submits a consolidated cargo document (CCN1)

- CBSA validates cargo document CCN1
- CBSA sends Notice to the carrier indicating CCN1 is Accepted
- CCN1 status is set to **Not Matched** (consolidated cargo)
- CBSA sends a Completeness Notice to the carrier indicating CCN1 is **Not Matched**.



2. Basic Flow

Step 3: Freight Forwarder submits House Bill Close message

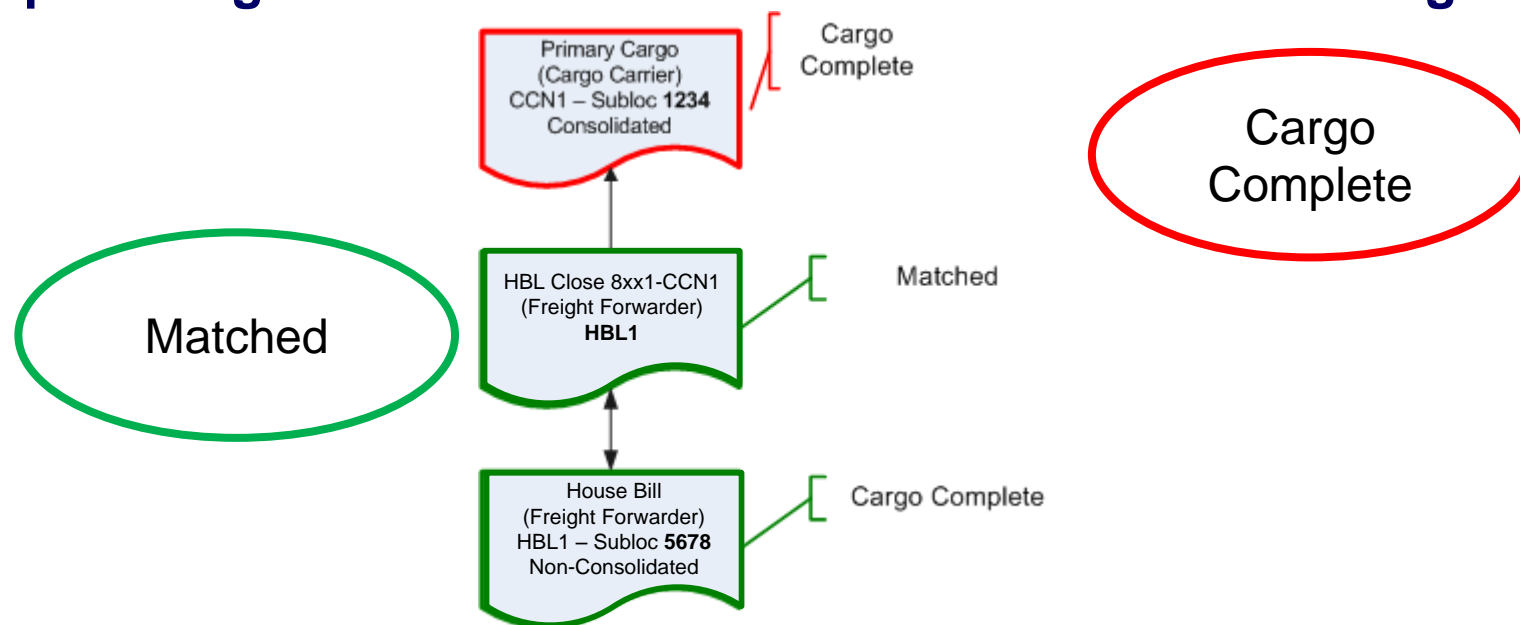

Freight Forwarder submits House Bill Close message

- CBSA validates House Bill Close document
- CBSA sends a Notice to the Freight Forwarder indicating that the House Bill Close is accepted
- CCN1 status is set to **Cargo Complete**
- CBSA sends a Completeness Notice to the carrier indicating CCN1 is **Cargo Complete**.
- CBSA sends a Completeness Notice to the Freight Forwarder indicating that the House Bill Close is **Matched**



2. Basic Flow

Step 4: Importer/BrokerA submits PARS for HBL1

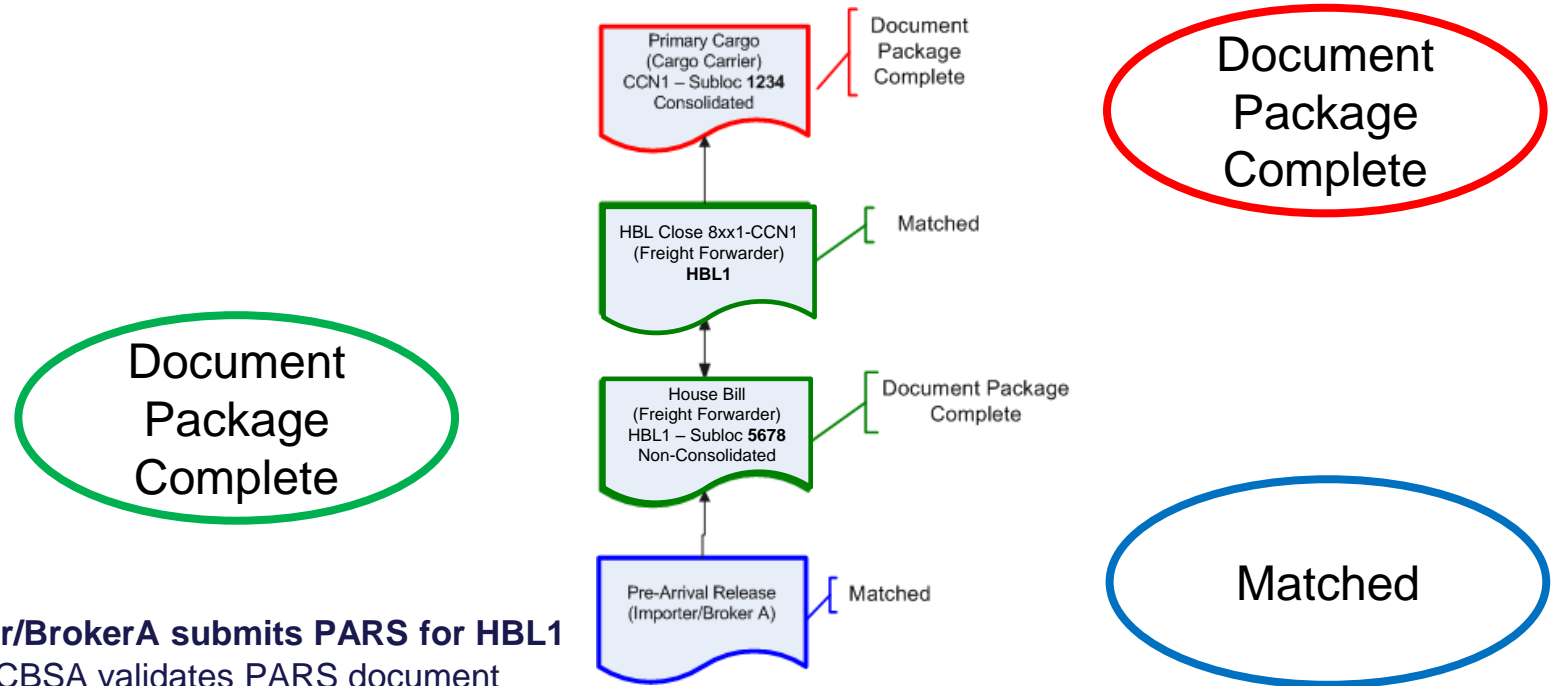

Importer/BrokerA submits PARS for HBL1

- CBSA validates PARS document
- CBSA sends a Notice to the importer/brokerA indicating that the PARS for HBL1 is accepted
- CBSA sets PARS to **Matched**
- CBSA sets HBL1 status to **Document Package Complete**
- CBSA sets CCN1 status to **Document Package Complete**
- CBSA sends a Notice to the importer/brokerA indicating that the PARS for HBL1 is **Matched**
- CBSA sends a Completeness Notice to the Freight Forwarder indicating HBL1 is **Document Package Complete.**
- CBSA sends a Completeness Notice to the Cargo Carrier indicating CCN1 is **Document Package Complete.**



2. Basic Flow

Step 5: Carrier submits Conveyance document Documents submitted

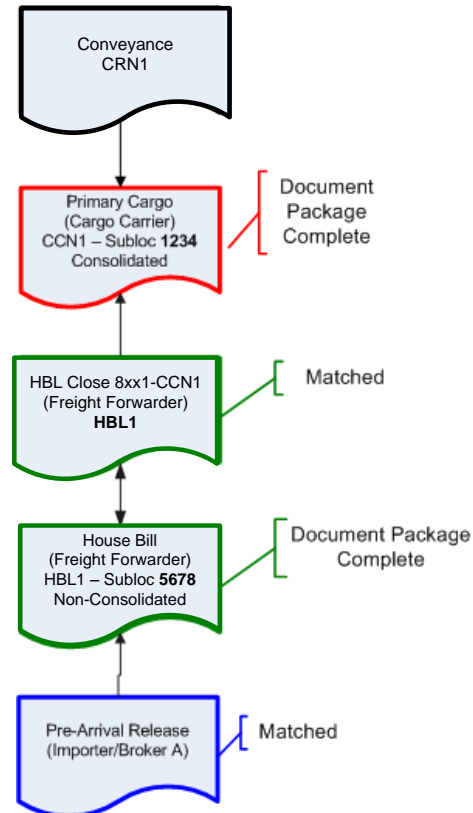

Carrier submits Conveyance

- CBSA validates Conveyance document
- CBSA sends a Notice to the Carrier indicating that the Conveyance document is accepted



2. Basic Flow

Step 5: Conveyance is Arrived

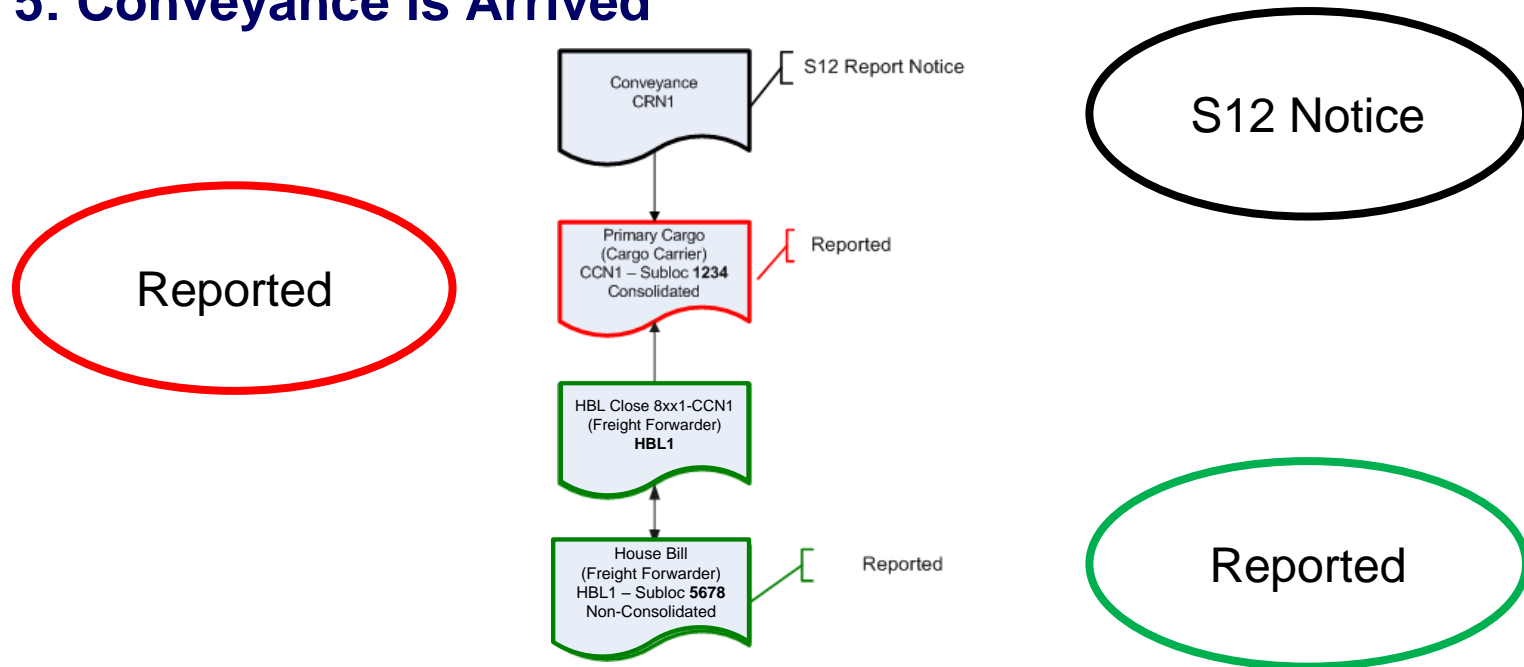

The Transporting Carrier will receive the following notices:

- CBSA sends an **S12** Notice to the Carrier

The Freight Forwarder will receive the following notices:

- House Bill HBL1 is **Reported**

The Cargo Carrier will receive the following notices:

- CCN 1 is **Reported**

2. Basic Flow

Step 6: Conveyance is Arrived (cont.)

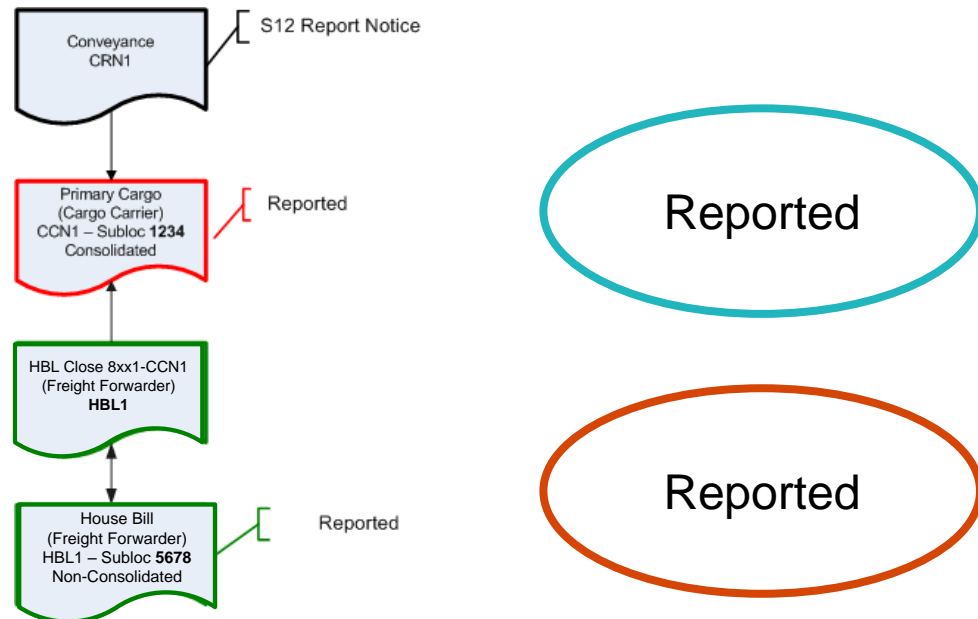

The **Warehouse (Subloc 1234)** will receive the following notices:

- CCN 1 is **Reported**
 - This message will be sent to the Warehouse owner of the Subloc quoted on the Primary CCN(CCN1)

The **Warehouse (Subloc 5678)** will receive the following notices:

- HBL1 is **Reported**
 - This message will be sent to the Warehouse owner of the Subloc quoted on the House Bill (HBL1)



2. Basic Flow

Step 7: Cargo Carrier transports Cargo CCN1 to Warehouse

Subloc 1234

Warehouse 1234 submits Warehouse Arrival Certification Msg

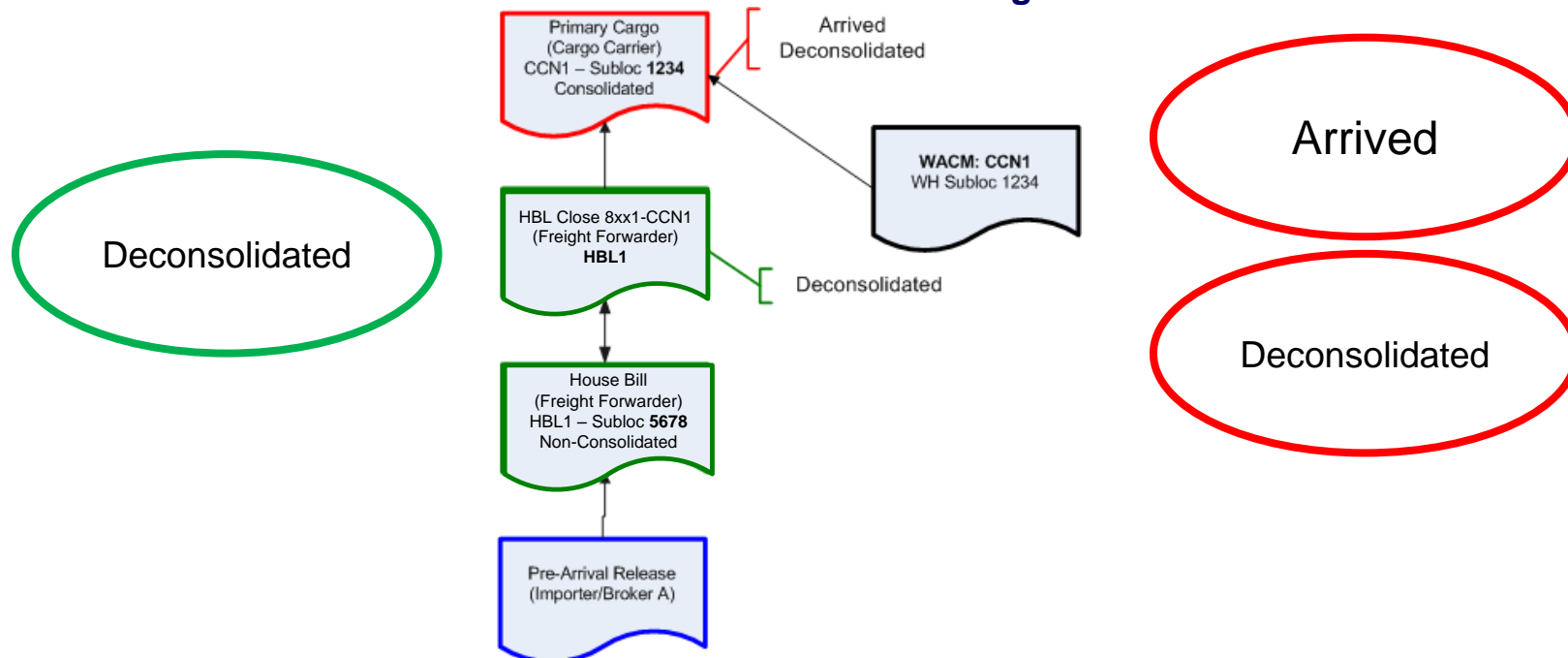

The **Cargo Carrier** will receive the following notices:

- CCN 1 is **Arrived**
- CCN 1 is **Deconsolidated**

The **Freight Forwarder** will receive the following notices:

- House Bill Close (HBL Close) is **Deconsolidated**



2. Basic Flow

Step 7: Cargo Carrier transports Cargo CCN1 to Warehouse Subloc 1234 (cont.)

Warehouse 1234 submits Warehouse Arrival Certification Msg

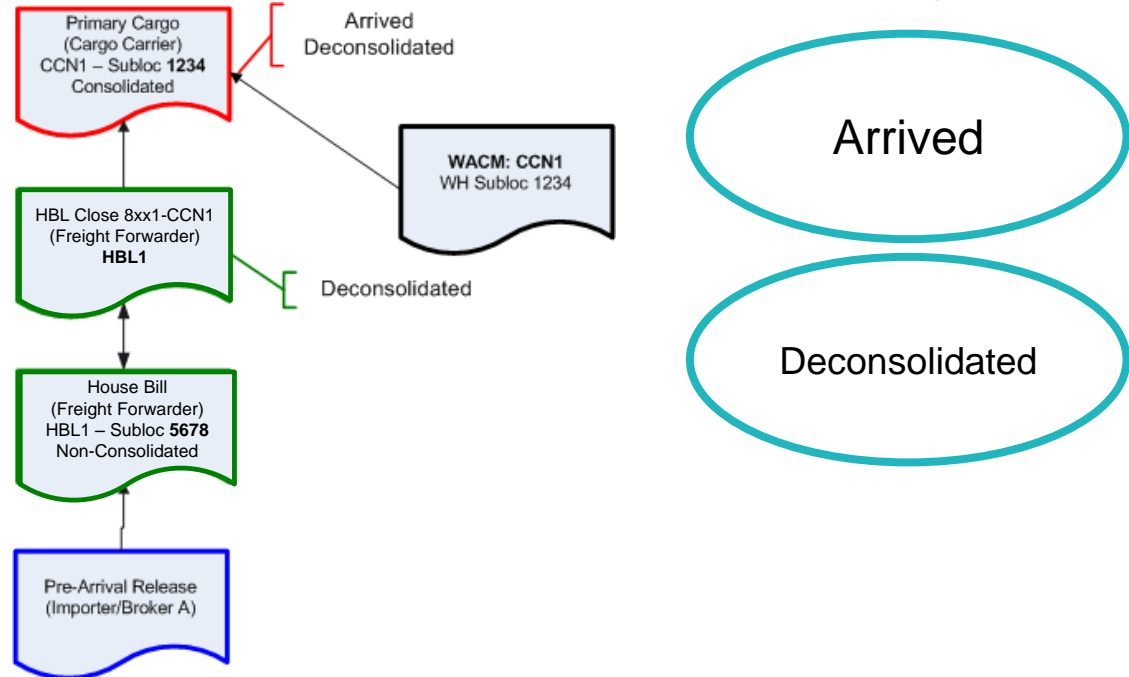

The **Warehouse (Subloc 1234)** will receive the following notices:

- CCN 1 is **Arrived**
- CCN 1 is **Deconsolidated**



2. Basic Flow

Step 8: Freight Forwarder transports Cargo HBL1 to Warehouse Subloc 5678

Warehouse submits Warehouse Arrival Certification Msg

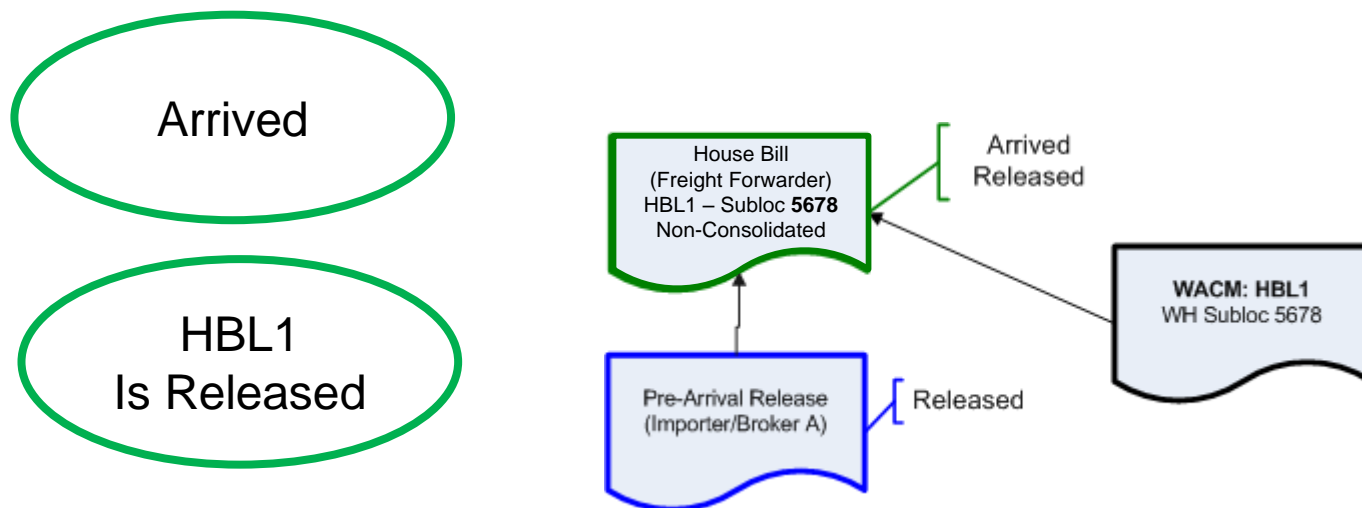

The **Freight Forwarder** will receive the following notices:

- HBL1 is **Arrived**
- HBL1 is **Released**



2. Basic Flow

Step 8: Freight Forwarder transports Cargo HBL1 to Warehouse Subloc 5678 (Cont.)

Warehouse submits Warehouse Arrival Certification Msg

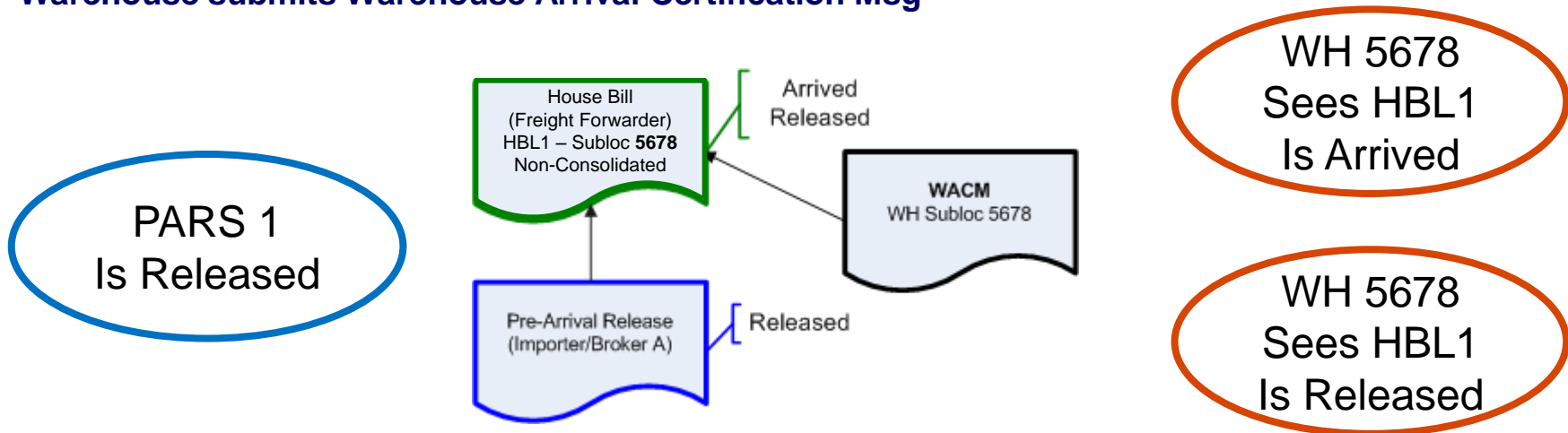

The **Warehouse (Subloc 5678)** will receive the following notices:

- HBL1 is **Arrived**
- HBL1 is **Released**

The **Importer/Broker A** will receive the following notices:

- PARS 1 is **Released**



Final View after all Warehouse Arrivals

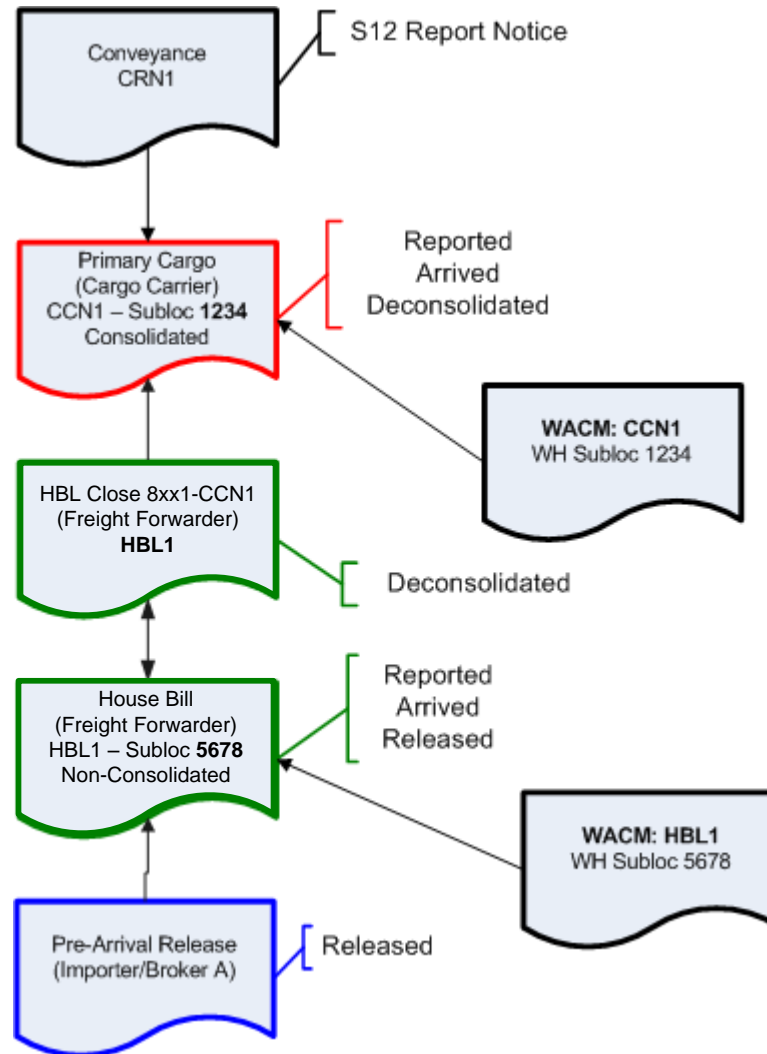



3. Release Quoting House Bill Referred for Exam (Held)



3. Release Quoting House Bill Referred for Exam (Held)

Step 8a (Continues from 1.Basic Flow Step 7): Freight Forwarder transports Cargo HBL1 to Warehouse Subloc 5678 (Cont.)

Warehouse submits Warehouse Arrival Certification Msg

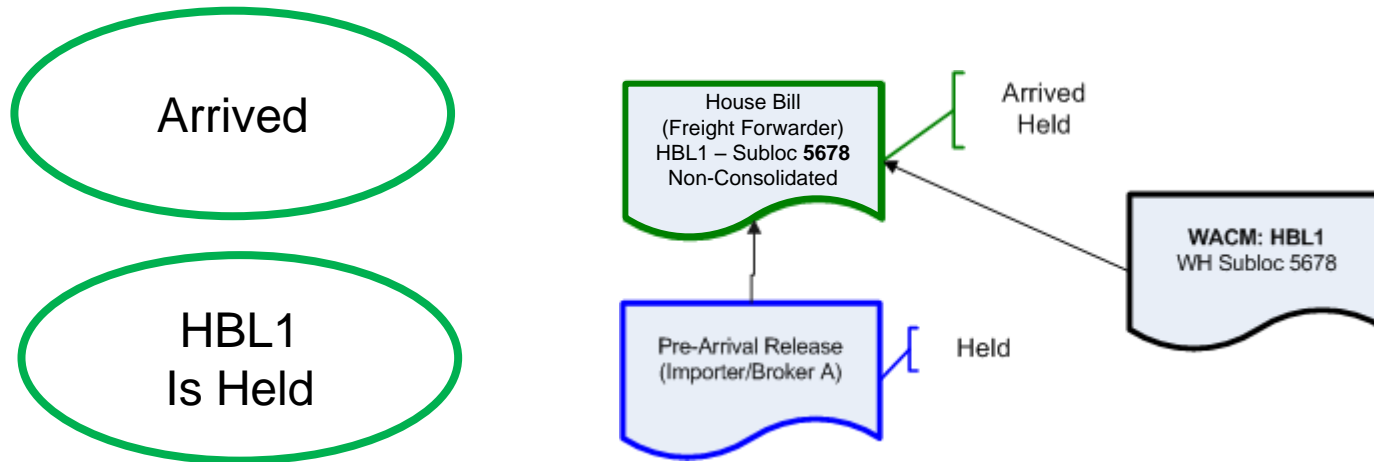

The **Freight Forwarder** will receive the following notices:

- HBL1 is **Arrived**
- HBL1 is **Held**



3. Release Quoting House Bill Referred for Exam (Held)

Step 8a: Freight Forwarder transports Cargo HBL2 to Warehouse Subloc 5678 (Cont.)

Warehouse submits Warehouse Arrival Certification Msg

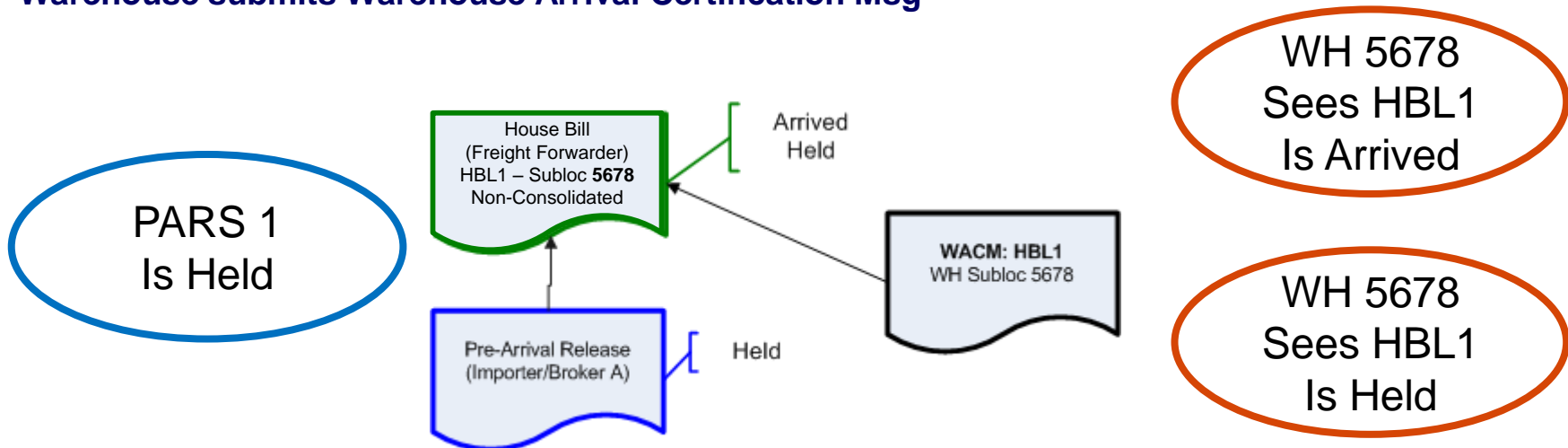

The **Warehouse (Subloc 5678)** will receive the following notices:

- HBL1 is **Arrived**
- HBL1 is **Held**

The **Importer/Broker A** will receive the following notices:

- PARS 1 is **Held**



3. Release Quoting House Bill Referred for Exam (Held)

Step 10: Release decision is made

After performing an exam CBSA decides to Release CCN 2

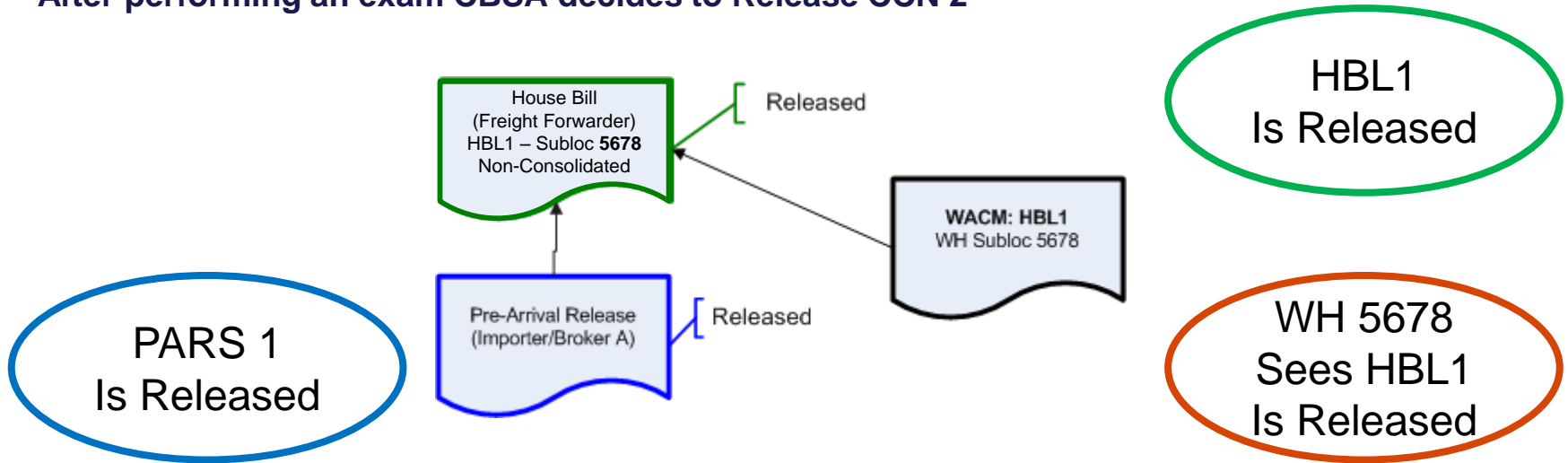

The **Freight Forwarder** will receive the following notices:

- House Bill HBL1 is **Released**

The **Importer/Broker B** will receive the following notices:

- PARS 1 is **Released**

The **Warehouse (Subloc 5678)** will receive the following notices:

- HBL1 is **Released**



4. Two-Tier Consolidation Post-Arrival Release



4. Two-Tier Consolidation

Step 1: Freight Forwarder A submits non-consolidated house bill HBL2

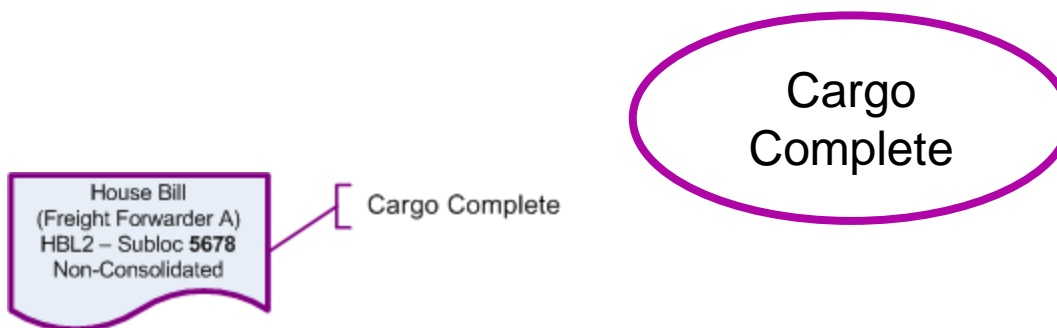

Freight Forwarder A submits non-consolidated house bills (HBL2)

- CBSA validates house bill document
- CBSA sends a notice to Freight Forwarder A indicating HBL2 is Accepted
- HBL2 status is set to **Cargo Complete** (non-consolidated house bill)
- CBSA sends a Completeness Notices to the Freight Forwarder A indicating HBL2 is **Cargo Complete**.



4. Two-Tier Consolidation

Step 2: Freight Forwarder B submits consolidated house bill HBL1

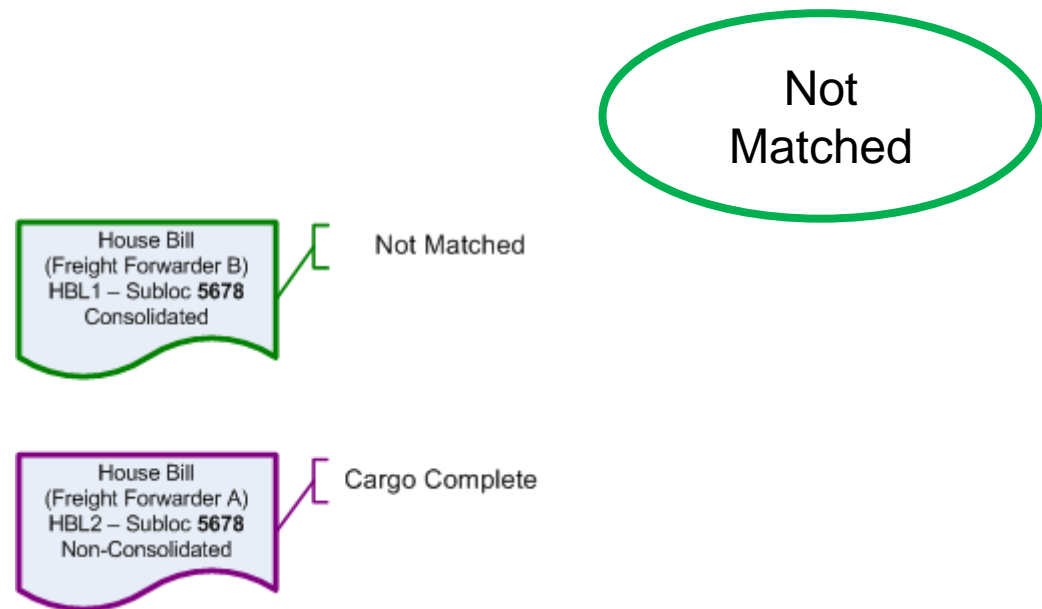

Freight Forwarder B submits consolidated house bill (HBL1)

- CBSA validates house bill document
- CBSA sends a notice to the Freight Forwarder B indicating HBL1 is Accepted
- HBL1 status is set to **Not Matched** (consolidated house bill)
- CBSA sends a Completeness Notices to the **Freight Forwarder B** indicating HBL1 is **Not Matched**.

4. Two-Tier Consolidation

Step 3: Freight Forwarder A submits House Bill Close 1

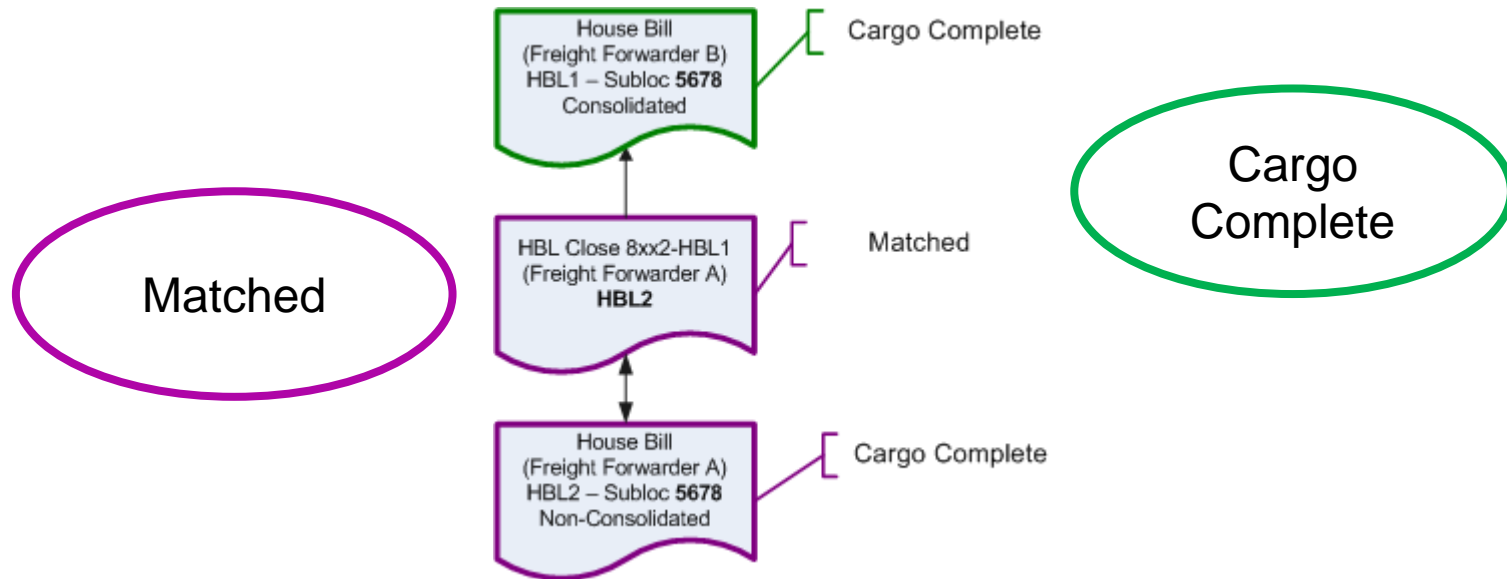

The Freight Forwarder A submits House Bill Close message

- CBSA validates House Bill Close document
- CBSA sends a Notice to the Freight Forwarder A indicating that the House Bill Close is Accepted
- House Bill Close status is set to **Matched**. HBL1 status is set to **Cargo Complete** (non-consolidated house bill)
- CBSA sends a Completeness Notices to the **Freight Forwarder A** indicating House Bill Close is **Matched**.
- CBSA sends a Completeness Notices to the **Freight Forwarder B** indicating HBL1 is **Cargo Complete**.



4. Two-Tier Consolidation

Step 4: Carrier submits a consolidated cargo document

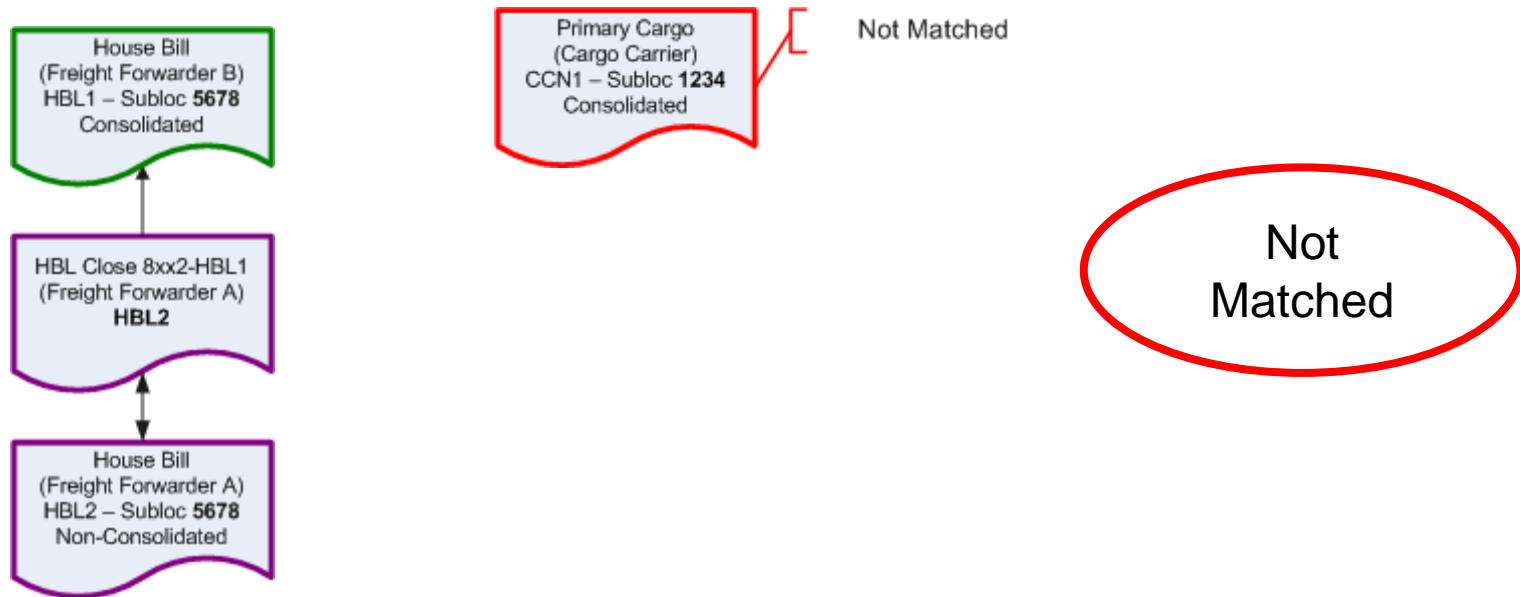

Carrier submits a consolidated cargo document (CCN1)

- CBSA validates cargo document CCN1
- CBSA sends Notice to the carrier indicating CCN1 is Accepted
- CCN1 status is set to **Not Matched** (consolidated cargo)
- CBSA sends a Completeness Notice to the carrier indicating CCN1 is **Not Matched**.



4. Two-Tier Consolidation

Step 5: Freight Forwarder B submits House Bill Close message

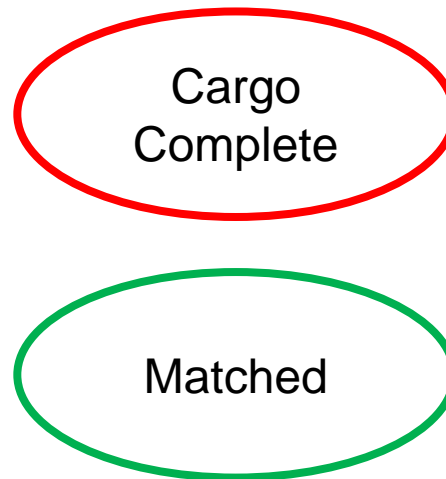

Freight Forwarder B submits House Bill Close message

- CBSA validates House Bill Close document
- CBSA sends a Notice to Freight Forwarder B indicating that the House Bill Close is accepted
- CCN1 status is set to **Cargo Complete**
- CBSA sends a Completeness Notice to the carrier indicating CCN1 is **Cargo Complete**.
- CBSA sends a Completeness Notice to the Freight Forwarder B indicating that the House Bill Close is **Matched**

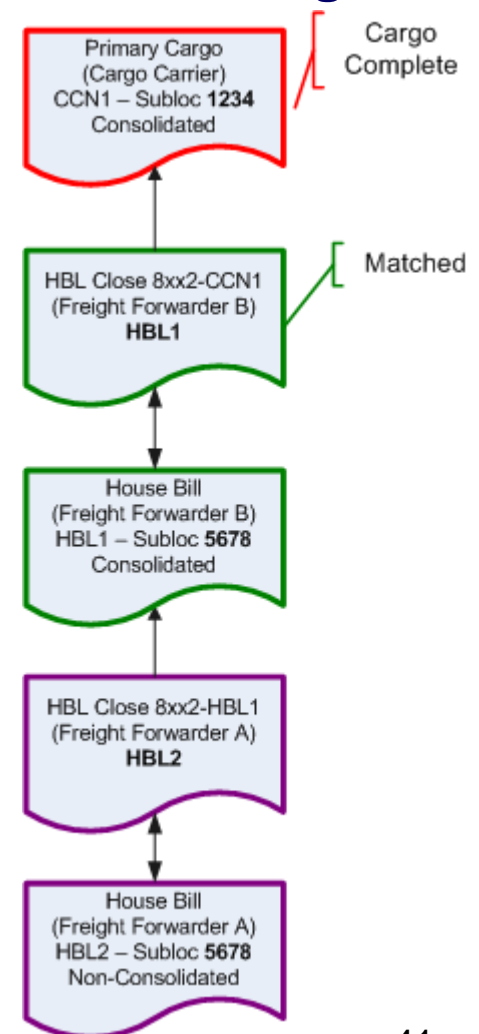



4. Two-Tier Consolidation

Step 6: Carrier submits Conveyance document

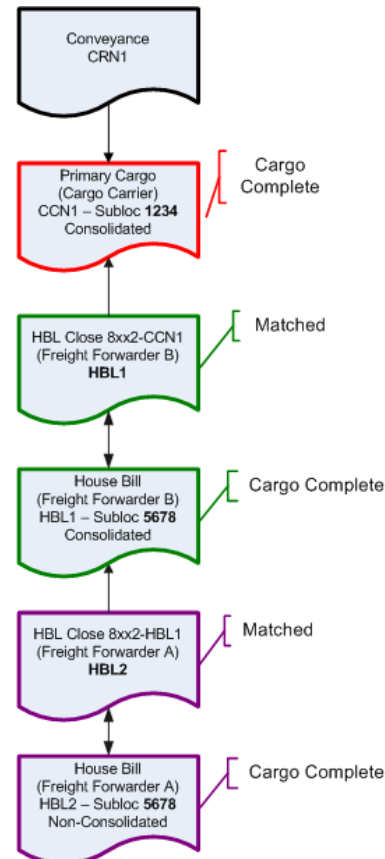

Carrier submits Conveyance

- CBSA validates Conveyance document
- CBSA sends a Notice to the Carrier indicating that the Conveyance document is accepted



4. Two-Tier Consolidation

Step 7: Transporting Carrier is Arrived at PIL by BSO

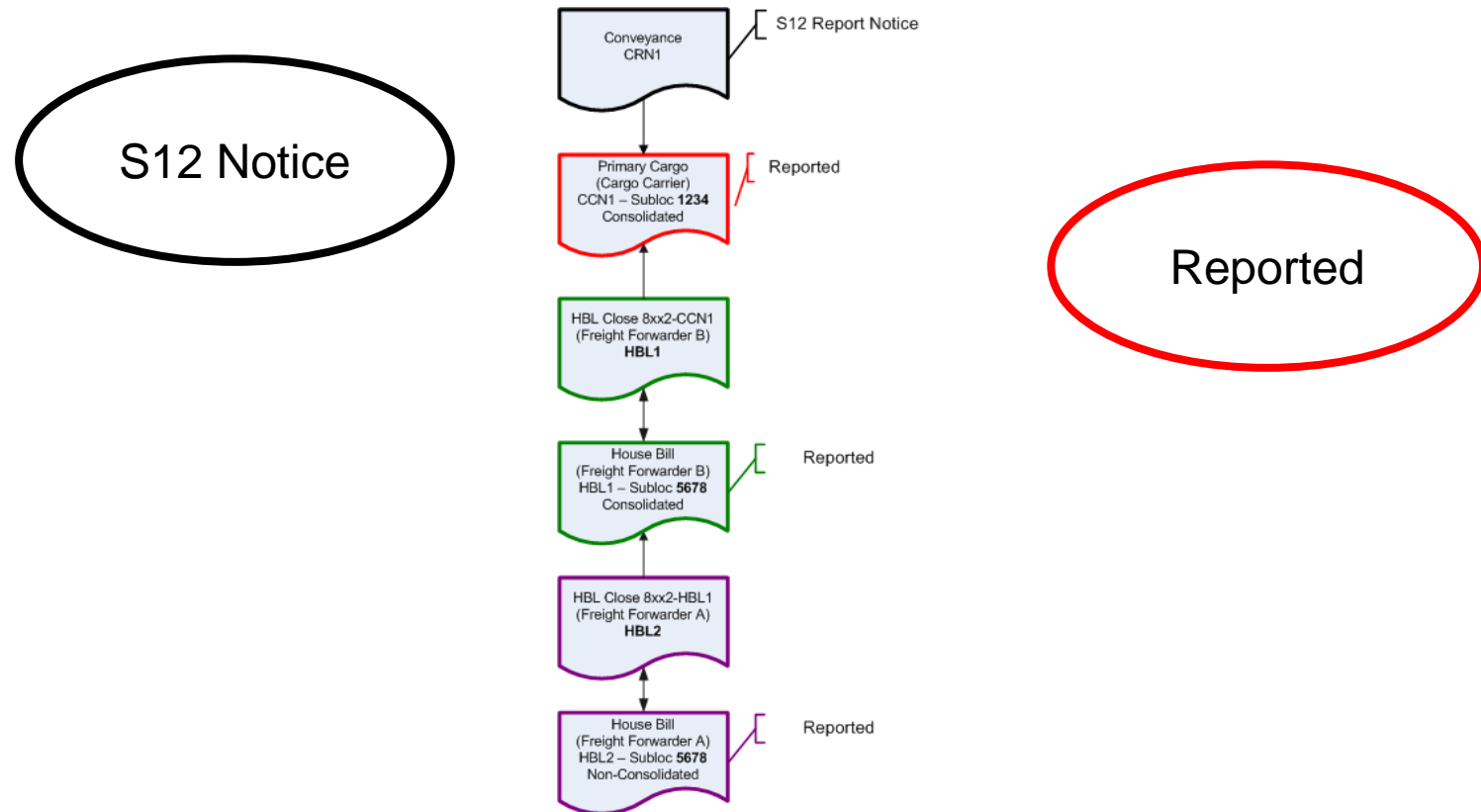

The Transporting Carrier will receive the following notices:

- CBSA sends an **S12** Notice to the Carrier

The **Cargo Carrier** will receive the following notices:

- CCN 1 is **Reported**



4. Two-Tier Consolidation

Step 7: Transporting Carrier is Arrived at PIL by BSO (cont.)

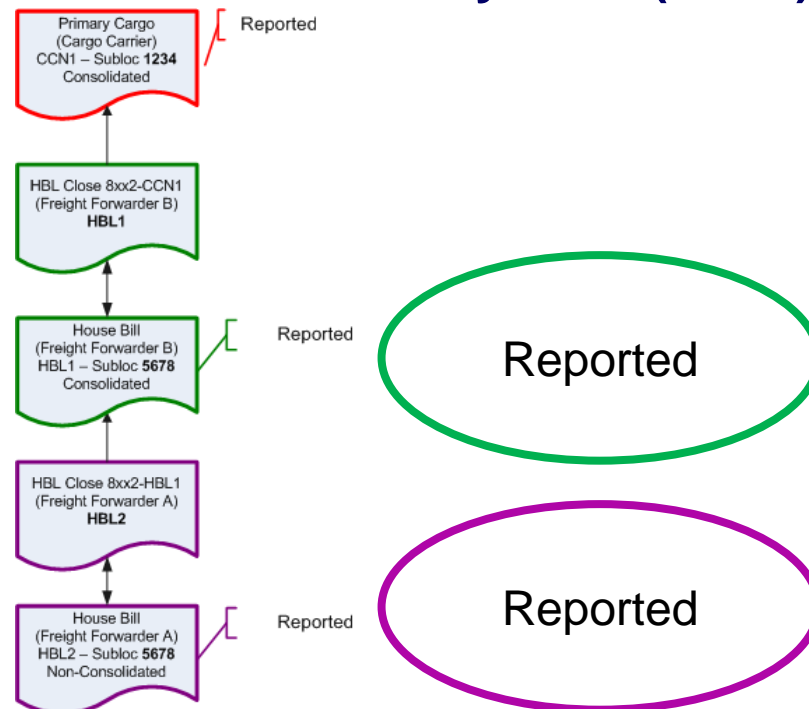

The **Freight Forwarder B** will receive the following notices:

- HBL1 is **Reported**
 - This message will be sent to the Warehouse owner of the Subloc quoted on the House Bill (HBL1)

The **Freight Forwarder A** will receive the following notices:

- HBL2 is **Reported**
 - This message will be sent to the Warehouse owner of the Subloc quoted on the House Bill (HBL2)



4. Two-Tier Consolidation

Step 7: Transporting Carrier is Arrived at PIL by BSO (cont.)

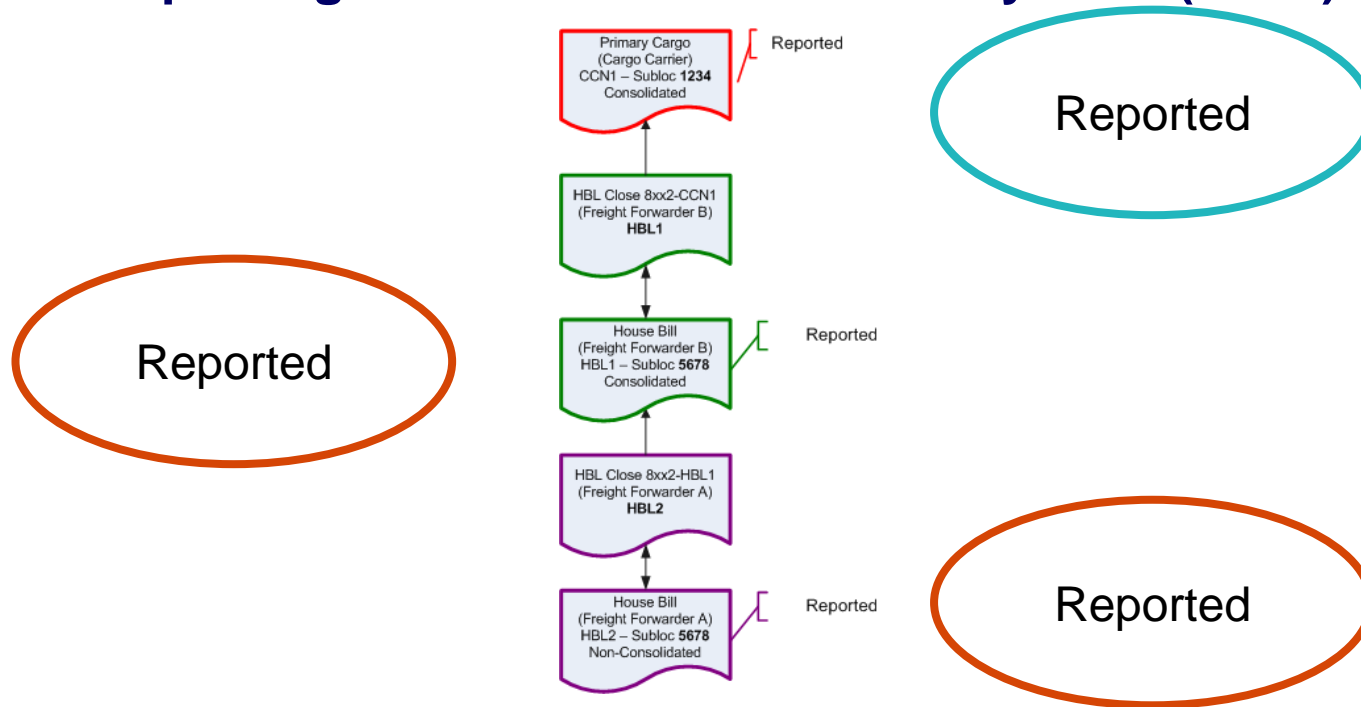

The **Warehouse (Subloc 1234)** will receive the following notices:

- CCN 1 is **Reported**
 - This message will be sent to the Warehouse owner of the Subloc quoted on the Primary CCN(CC1)

The **Warehouse (Subloc 5678)** will receive the following notices:

- HBL1 is **Reported**
 - This message will be sent to the Warehouse owner of the Subloc quoted on the House Bill (HBL1)
- HBL2 is **Reported**
 - This message will be sent to the Warehouse owner of the Subloc quoted on the House Bill (HBL2)



4. Two-Tier Consolidation

Step 8: Cargo Carrier transports Cargo CCN1 to an Inland Warehouse Subloc 1234

Warehouse 1234 submits Warehouse Arrival Certification Msg

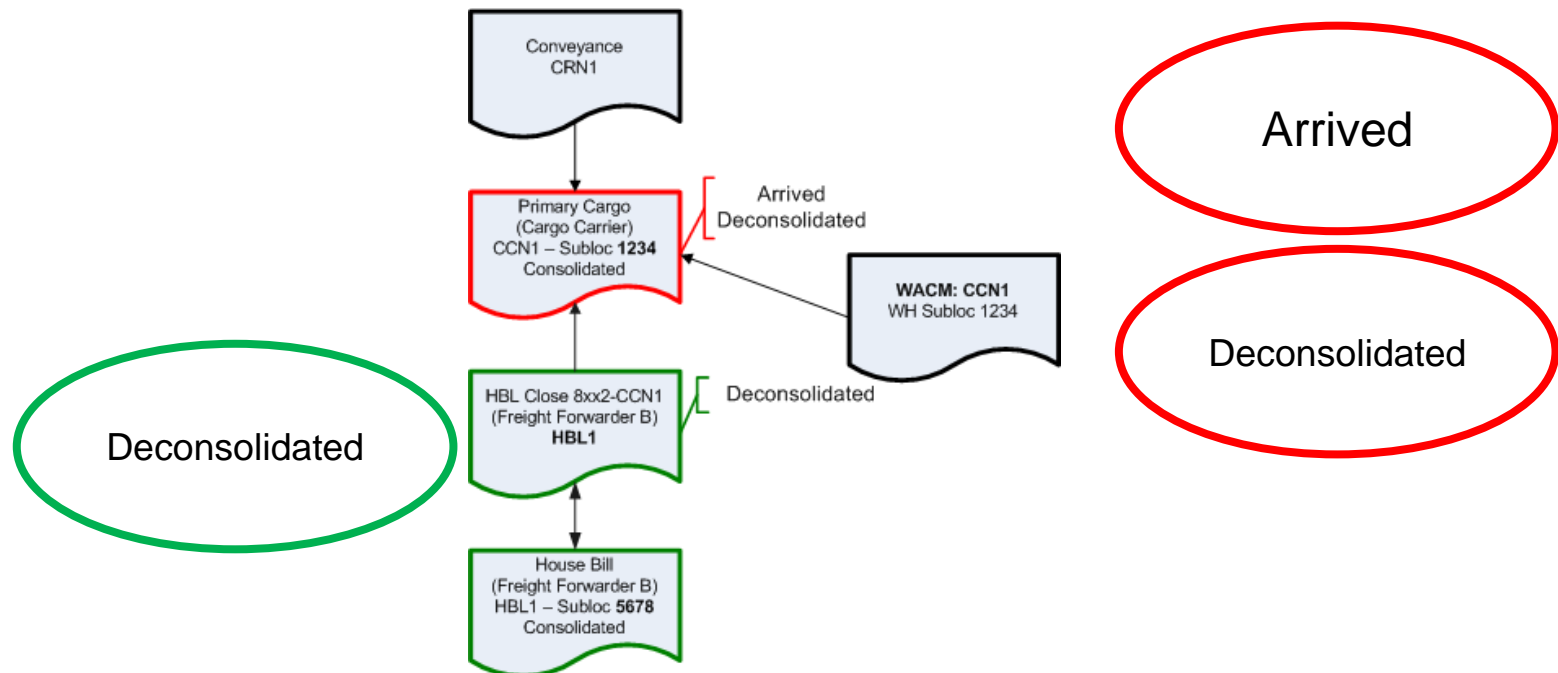

The **Cargo Carrier** will receive the following notices:

- CCN 1 is **Arrived**
- CCN 1 is **Deconsolidated**

The **Freight Forwarder B** will receive the following notices:

- House Bill Close (HBL Close) is **Deconsolidated**



4. Two-Tier Consolidation

Step 8: Cargo Carrier transports Cargo CCN1 to an Inland Warehouse Subloc 1234 (Cont.)

Warehouse 1234 submits Warehouse Arrival Certification Msg

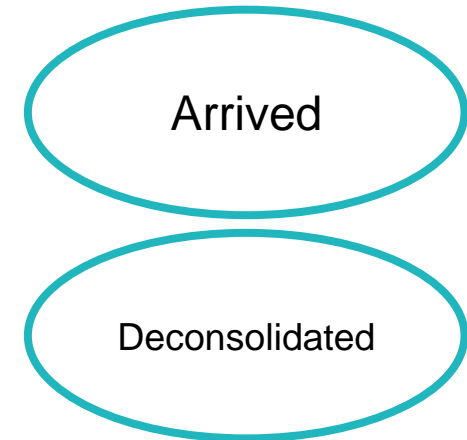
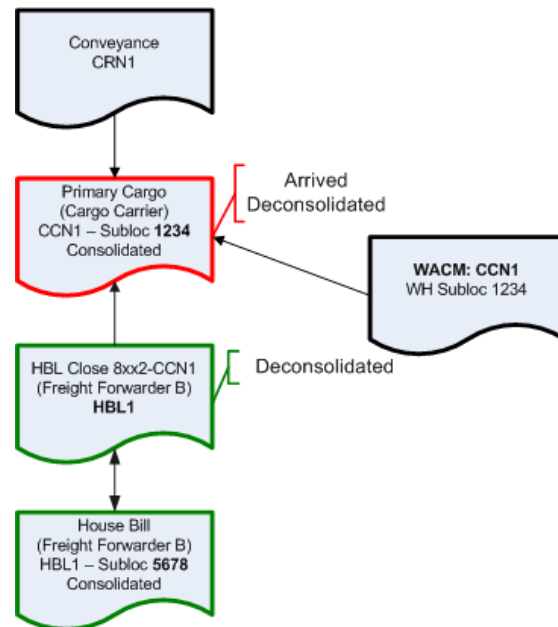

The **Warehouse (Subloc 1234)** will receive the following notices:

- CCN 1 is **Arrived**
- CCN 1 is **Deconsolidated**



4. Two-Tier Consolidation

Step 9: Freight Forwarder B transports Cargo HBL1 to Warehouse Subloc 5678

Warehouse submits Warehouse Arrival Certification Msg

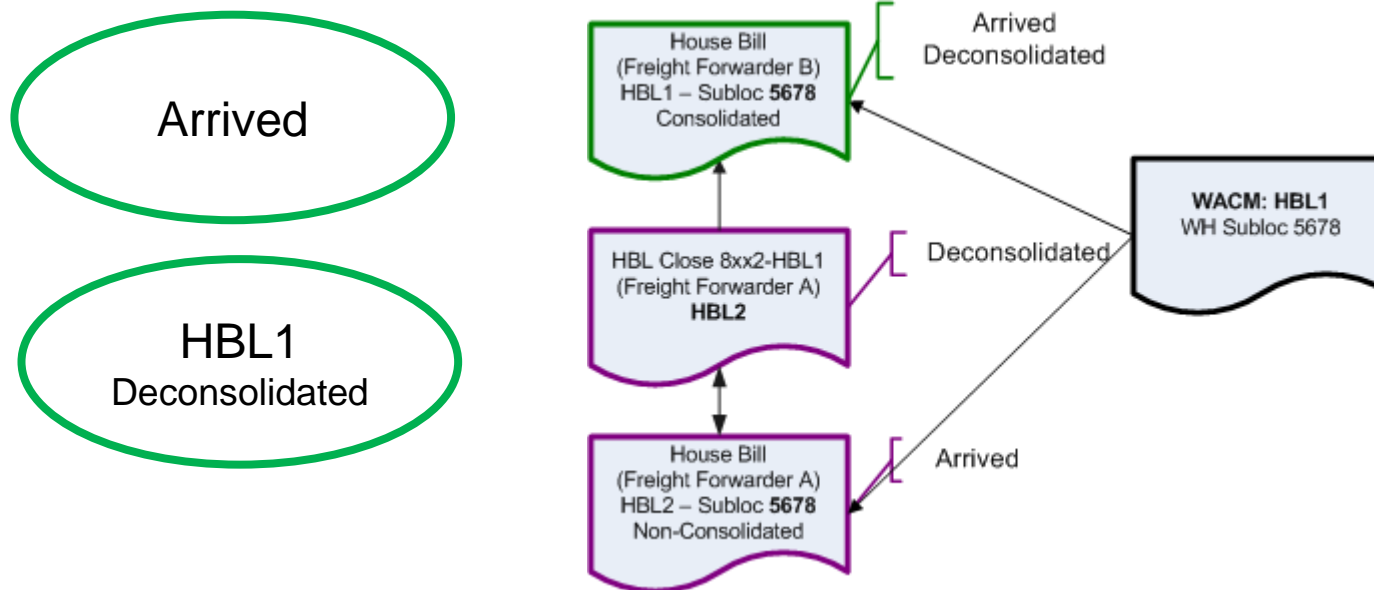

The **Freight Forwarder B** will receive the following notices:

- HBL1 is **Arrived**
- HBL1 is **Deconsolidated**



4. Two-Tier Consolidation

Step 9: Freight Forwarder B transports Cargo HBL1 to Warehouse Subloc 5678 (Cont.)

Warehouse submits Warehouse Arrival Certification Msg

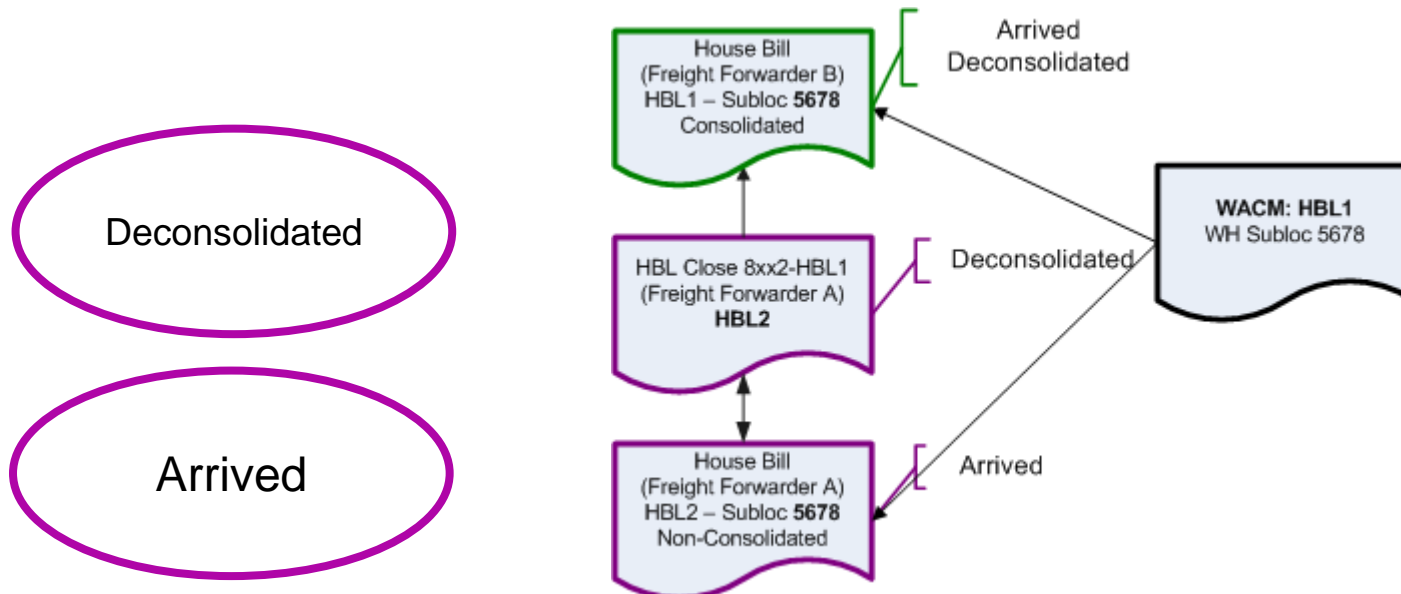

The **Freight Forwarder A** will receive the following notices:

- HBL Close 8xx2-HBL1 is **Deconsolidated**
- HBL2 is **Arrived**



4. Two-Tier Consolidation

Step 9: Freight Forwarder B transports Cargo HBL1 to Warehouse Subloc 5678 (Cont.)

Warehouse submits Warehouse Arrival Certification Msg

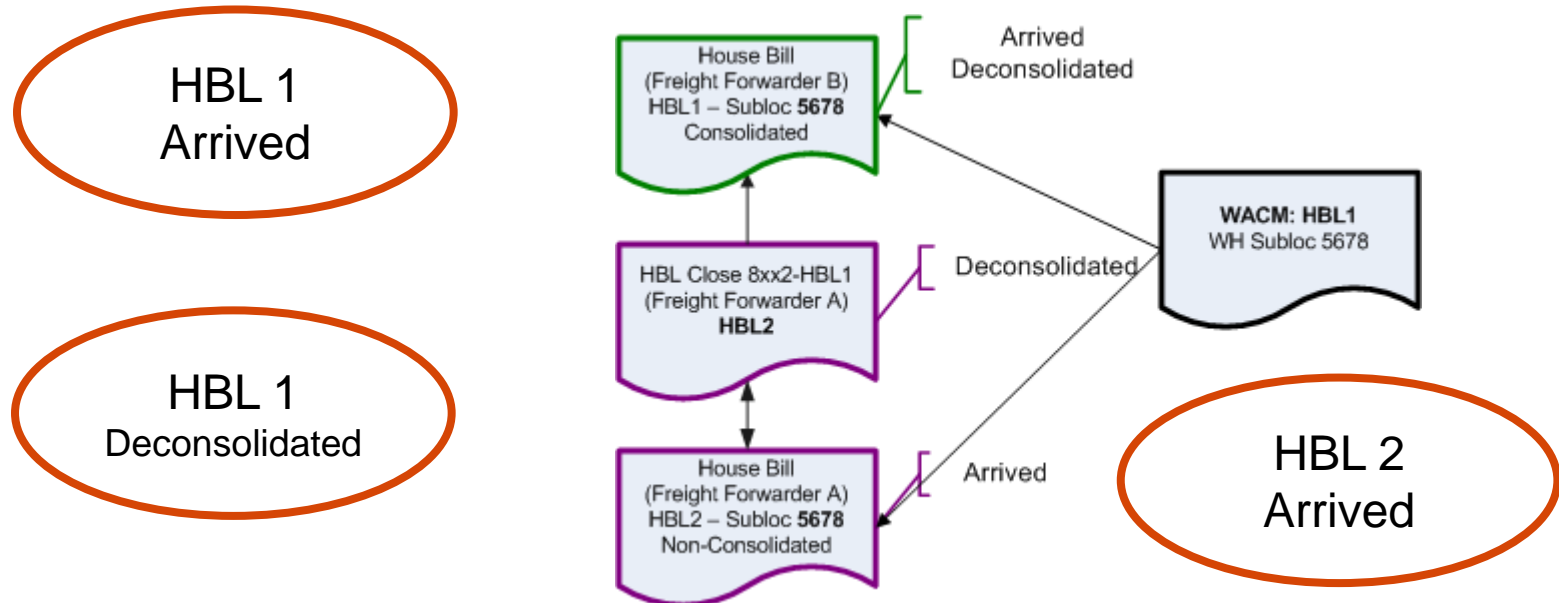

The **Warehouse (Subloc 5678)** will receive the following notices:

- HBL1 is **Arrived**
- HBL1 is **Deconsolidated**
- HBL2 is **Arrived**



4. Two-Tier Consolidation

Step 10: Importer/ Broker A submits RMD for HBL2

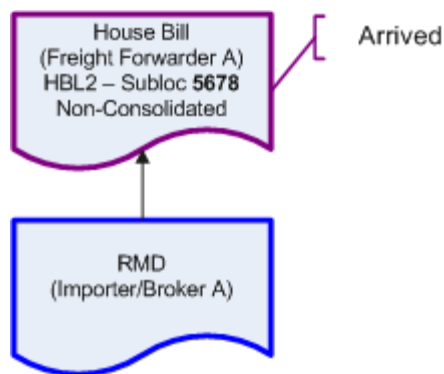

Importer/Broker A submits RMD for HBL2

- CBSA validates RMD document
- CBSA sends a Notice to the importer/broker A indicating that the RMD for HBL2 is Accepted



4. Two-Tier Consolidation

Step 11: CBSA makes a Release Decision

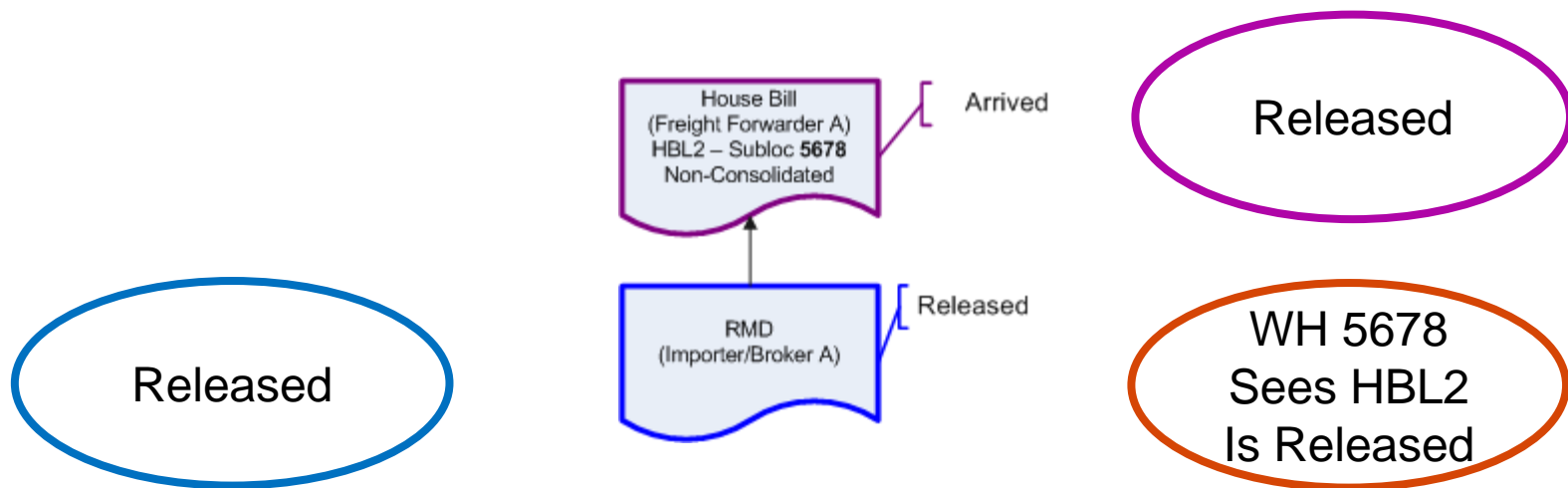

The **Importer/Broker** will receive the following notices:

- RMD is Released

The **Freight Forwarder A** will receive the following notices:

- HBL2 is Released

The **Warehouse (Subloc 5678)** will receive the following notices:

- HBL2 is Released